

Contents

目錄

	Page No:
Product Specification Guide ----- 圖冊使用說明	-01
Diameter (mm) : $\phi 13$ -----	-02
Diameter (mm) : $\phi 16$ -----	-02
Diameter (mm) : $\phi 19$ -----	-03
Diameter (mm) : $\phi 22$ -----	-05
Diameter (mm) : $\phi 25$ -----	-06
Diameter (mm) : $\phi 30$ -----	-07
Diameter (mm) : $\phi 35$ -----	-09
Diameter (mm) : $\phi 38$ -----	-10
Diameter (mm) : $\phi 40$ -----	-11
Diameter (mm) : $\phi 45$ -----	-12
Diameter (mm) : $\phi 50$ -----	-13
Diameter (mm) : $\phi 60$ -----	-14
Fragrance Caps -----	-15
Custom Tube Caps -----	-16
Labelling & Tube end sealing Styles -----	-17
Tube specification and volume comparison table -----	-18~19
Tube specification and volume comparison table -----	-20~21

Product Specification Guide

圖冊使用說明:

Tube Head No.: A1603 (管牙型產品編號)
 Cap No.: A161 (蓋產品編號)

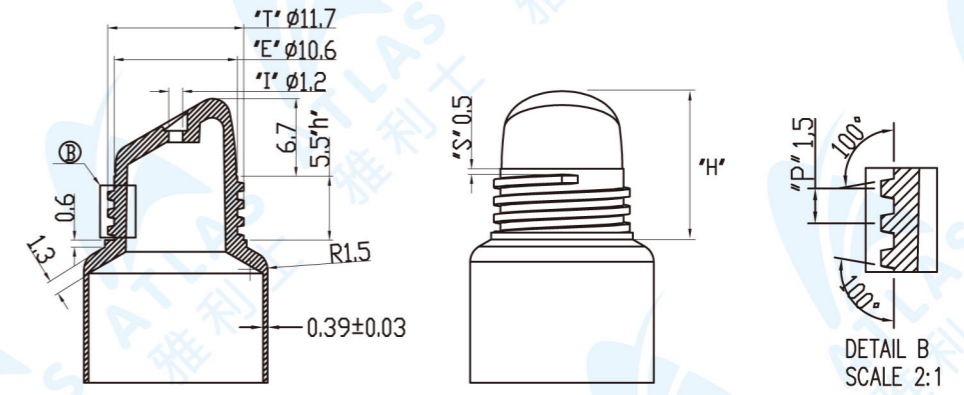

A1603

Tube (管): (附圖)

- I: Orifice (孔徑)
- T: Thread diameter (牙徑)
- E: Head diameter without thread (牙底徑)
- S: Thread starting position (起牙位置)
- P: Thread separation (牙距)
- H: Height (牙高) (圖紙上通常只標了牙板+注咀的整體高度 H=base+h)

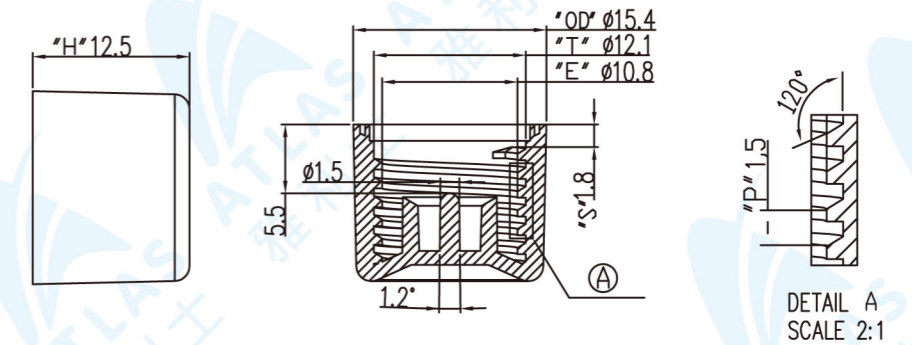

A161

Cap (蓋): (附圖)

- T: Inner diameter without thread (牙底徑與管相反)
- E: Inner diameter to thread (牙徑與管相反)
- S: Thread starting position (起牙位置)
- P: Thread to cap base length (牙距)
- H: Cap height (蓋高)
- OD: Cap outer diameter (蓋外徑) (通常測量橢圓產品口部外徑時需測量兩邊)

Orifice seal type: (附圖)

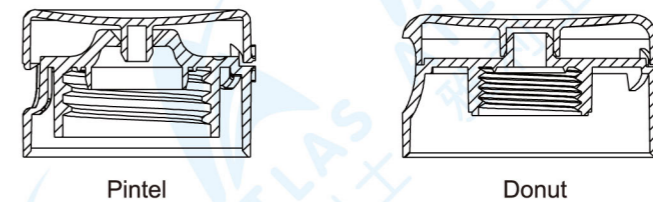

Pintel

Donut

Diameter (mm) : ø13

Tube head No.	A1301	Cap No.	A131
I ±0.2:	Ø1.5	I ±0.2:	Ø1.5
T ±0.2:	9.8	T ±0.2:	10.2
E ±0.2:	8.0	E ±0.2:	8.3
H ±0.2:	1.1+4.4+4.9	H ±0.2:	12.1
		OD ±0.2:	12.5

Tube head No.	A1302	Reverse Reusable / Tamper twist off
I ±0.2:	Ø1.8	
T ±0.2:	8.7	
E ±0.2:	6.0	
H ±0.2:	25.3	

Tube head No.	A1303	Cap No.	A132
I ±0.2:	Ø1.2	I ±0.2:	Ø1.2
T ±0.2:	5.9	T ±0.2:	6.2
E ±0.2:	4.7	E ±0.2:	5.1
H ±0.2:	0.5+4.0	H ±0.2:	10.9
		OD ±0.2:	12.7

Tube head No.	A1304	Cap No.	W131
I ±0.2:	Ø1.3	I ±0.2:	10.0
T ±0.2:	9.5	T ±0.2:	8.6
E ±0.2:	7.9	E ±0.2:	25.0
H ±0.2:	0.7+5.7+6.5	H ±0.2:	12.6

Tube head No.	A1308	Cap No.	A197
I ±0.2:	Ø1.0	I ±0.2:	Ø1.0
T ±0.2:	5.8	T ±0.2:	6.2
E ±0.2:	4.8	E ±0.2:	5.2
H ±0.2:	0.4+6.0+7.5	H ±0.2:	18.1
OD ±0.2:		OD ±0.2:	9.3

Tube head No.	A1307	Cap No.	A135 Child resistant cap Tamper Breakoff orifice
T ±0.2:	7.3	T ±0.2:	7.8
E ±0.2:	6.0	E ±0.2:	6.2
H ±0.2:	0.6+14.0	H ±0.2:	21.6
		OD ±0.2:	12.6

Tube head No.	A1306 (Push Cap) Tamper breakoff orifice	Cap No.	A134 Reusable Cap
I ±0.2:	Ø2.3	T ±0.2:	9.5
T ±0.2:	8.8	E ±0.2:	8.9
E ±0.2:	8.1	H ±0.2:	22.1
H ±0.2:	0.5+16.0	OD ±0.2:	11.3

Diameter (mm) : ø16

Tube head No.	A1601	Cap No.	A161
I ±0.2:	Ø1.0	I ±0.2:	Ø1.0
T ±0.2:	11.8	T ±0.2:	12.1
E ±0.2:	10.5	E ±0.2:	10.8
H ±0.2:	0.6+5.2	H ±0.2:	12.5
		OD ±0.2:	15.4

Tube head No.	A1602	Cap No.	W161A W161B Plug: Ø5.7
I ±0.2:	Ø6.6	I ±0.2:	Ø6.6
T ±0.2:	9.7	T ±0.2:	9.7
E ±0.2:	8.6	E ±0.2:	8.6
H ±0.2:	0.6+8.4	H ±0.2:	0.6+8.4

Tube head No.	A1603	Cap No.	A162 Matte
I ±0.2:	Ø1.2	I ±0.2:	Ø1.2
T ±0.2:	11.7	T ±0.2:	12.2
E ±0.2:	10.6	E ±0.2:	11
H ±0.2:	0.6+12.2	H ±0.2:	15.5
		OD ±0.2:	15.2

Tube head No.	A1604	Cap No.	A197
I ±0.2:	Ø1.0	I ±0.2:	Ø1.0
T ±0.2:	5.8	T ±0.2:	6.2
E ±0.2:	4.8	E ±0.2:	5.2
H ±0.2:	0.4+6.0+7.5	H ±0.2:	18.1
		OD ±0.2:	9.3

Tube head No.	A1605	Cap No.	A163
I ±0.2:	Ø2.0	I ±0.2:	Ø2.0
T ±0.2:	8.8	T ±0.2:	9.1
E ±0.2:	7.2	E ±0.2:	7.7
H ±0.2:	0.5+5.0	H ±0.2:	10.7
		OD ±0.2:	15.4

Tube head No.	A1606	Cap No.	A164
I ±0.2:	Ø1.5	I ±0.2:	Ø1.5
T ±0.2:	11.9	T ±0.2:	12.4
E ±0.2:	10.4	E ±0.2:	11.4
H ±0.2:	1.0+5.9+12.3	H ±0.2:	21.1
		OD ±0.2:	14.5

Tube head No.	A1607	Cap No.	W162
I ±0.2:	Ø4.8	Cap: I ±0.2:	Ø2.3
T ±0.2:	10.2	Tube: I ±0.2:	Ø2.0-5.0
E ±0.2:	8.2	T ±0.2:	10.8
H ±0.2:	0.5+5.1	E ±0.2:	9.3
		H ±0.2:	14.7
		OD ±0.2:	15.5

Diameter (mm) : ø19

Tube head No.	A1901, A1902	Cap No.	A191	A199 Ribbed	A199A
I ±0.2:	A1901: Ø4.8 A1902: Ø2.0-5.0	Plug: I ±0.2:	/	/	/
T ±0.2:	10.2	Tube: I ±0.2:	Ø2.0-5.0	Ø2.0-6.0	Ø2.0-6.0
E ±0.2:	8.2	T ±0.2:	10.6	10.9	10.9
H ±0.2:	0.5+5.1	E ±0.2:	8.7	9.3	9.3
		H ±0.2:	10.1	10.0	10.0
		OD ±0.2:	17.8	17.9	17.9
		Depth:	/	7.0	7.0

Cap No.	Plug 19-A221C	W192	19-A223A+B
Plug: I ±0.2:	Ø1.0	Ø1.0	Ø1.0
Tube: I ±0.2:	Ø4.8	Ø4.8	Ø4.8
T ±0.2:	4.9	10.4	10.7
E ±0.2:	4.8	9.1	9.2
H ±0.2:	13.4	25.8	43.6
OD ±0.2:	7.8	18.3	18.7

Tube head No.	A1903, A1913	Cap No.	A194 Ribbed
I ±0.2:	A1903: Ø1.2, Ø2.26 A1913: Ø1.2-2.5	Plug: I ±0.2:	/
T ±0.2:	14.5	Tube: I ±0.2:	Ø1.2-2.5
E ±0.2:	13.1	T ±0.2:	15.0
H ±0.2:	0.5+13.9	E ±0.2:	13.4
		H ±0.2:	17.2
		OD ±0.2:	18.0

Tube head No.	A1903-1	Cap No.	Plug A192B A192A Ribbed
I ±0.2:	Ø10.3	Plug: I ±0.2:	Ø1.5
T ±0.2:	14.3	Tube: I ±0.2:	Ø10.3
E ±0.2:	12.7	T ±0.2:	14.6
H ±0.2:	0.9+6.6	E ±0.2:	13.4
		H ±0.2:	17.7
		OD ±0.2:	18.3

Tube head No.	A1904	Cap No.	A195 : Gloss A195B: Matte	A196: Gloss A196B: Matte
I ±0.2:	Ø1.5, Ø3.0	Tube: I ±0.2:	Ø1.5	Ø1.5, Ø3.0
T ±0.2:	14.2	T ±0.2:	14.7	14.6
E ±0.2:	12.4	E ±0.2:	13.0	13.0
H ±0.2:	0.5+5.8+11.2	H ±0.2:	20.0	20.6
		OD ±0.2:	17.8	18.5

Tube head No.	A1906	Cap No.	W192	A223A+B
I ±0.2:	Ø1.0, Ø1.5	Tube: I ±0.2:	Ø1.0, Ø1.5	Ø1.0, Ø1.5
T ±0.2:	10.2	T ±0.2:	10.4	10.7
E ±0.2:	8.3	E ±0.2:	9.1	9.2
H ±0.2:	0.5+5.1+8.1	H ±0.2:	25.8	43.6
		OD ±0.2:	18.3	18.7

Tube head No.	A1907	Cap No.	A193 Matte
I ±0.2:	Ø1.0	Tube: I ±0.2:	Ø1.0
T ±0.2:	7.9	T ±0.2:	8.3
E ±0.2:	6.4	E ±0.2:	6.9
H ±0.2:	3.5+17.7	H ±0.2:	22.7
Shoulder OD ±0.2:	16.7	OD ±0.2:	19.0

Tube head No.	A1908	Cap No.	A197
I ±0.2:	Ø1.0	Tube: I ±0.2:	Ø1.0
T ±0.2:	5.8	T ±0.2:	6.2
E ±0.2:	4.8	E ±0.2:	5.2
H ±0.2:	0.6+5.8+7.5	H ±0.2:	18.1
		OD ±0.2:	9.3

Diameter (mm) : ø22



Tube head No.	A1909 Tamper twist off	Tube head No.	A1910	Cap No.	Brush Plug W-BB094	Ball Plug W-Q060	Sponge Plug W-BC103
I ±0.2:	Ø2.7	I ±0.2:	Ø8.8	Tube: I ±0.2:	Ø8.8	Ø8.8	Ø8.8
T ±0.2:	10.4	T ±0.2:	12.2	T ±0.2:	8.9	8.9	8.9
E ±0.2:	6.3	E ±0.2:	10.7	E ±0.2:	8.8	8.8	8.8
H ±0.2:	19.2	H ±0.2:	0.5+5.3	H ±0.2:	34.8	25.1	26.7
				OD ±0.2:	11.0	11.0	11.0



Tube head No.	A2205	Cap No.	A224 A+B Gloss	Tube head No.	A2201, A2202	Cap No.	W221	Plug: A221C
I ±0.2:	Ø1.5, Ø1.5	Tube: I ±0.2:	Ø1.0, Ø1.5	I ±0.2:	A2201: Ø4.8	Tube: I ±0.2:	Ø2.0-5.0	Ø1.0
T ±0.2:	8.0	T ±0.2:	8.4	T ±0.2:	A2202: 2.0-Ø5.0	T ±0.2:	10.5	Ø4.8
E ±0.2:	6.1	E ±0.2:	6.7	E ±0.2:	10.2	E ±0.2:	8.6	4.9
H ±0.2:	0.7+18.3	H ±0.2:	23.5	H ±0.2:	8.2	H ±0.2:	11.0	4.8
		OD ±0.2:	16.7	H ±0.2:	0.5+5.1	OD ±0.2:	20.4	13.4
								7.8



Tube head No.	A1912	Cap No.	A190	Cap No.	Plug W-Q079	Cap:A	Cap:B	Cap:C	Cap:D
I ±0.2:	Ø1.0, Ø1.5	Tube: I ±0.2:	Ø1.0, Ø1.5	Tube: I ±0.2:	Ø8.8	Ø8.8	Ø8.8	Ø8.8	Ø8.8
T ±0.2:	8.0	T ±0.2:	8.4	T ±0.2:	8.9	12.5	12.5	12.5	12.5
E ±0.2:	6.1	E ±0.2:	6.7	E ±0.2:	8.8	11.4	11.3	11.1	11.6
H ±0.2:	0.5+18.3	H ±0.2:	23.5	H ±0.2:	37.9	35.1	34.3	34.7	23.9
		OD ±0.2:	16.7	OD ±0.2:	11.0	14.4	15.3	14.6	15.0



Tube head No.	A2205	Cap No.	A190 A190B Glass Matte	Tube head No.	A2206	Cap No.	W192	A223A+B	A222A+B
I ±0.2:	Ø1.0, Ø1.5	Tube: I ±0.2:	Ø1.0, Ø1.5	I ±0.2:	Ø1.0, Ø1.5	Tube: I ±0.2:	Ø1.0, Ø1.5	Ø1.0, Ø1.5	Ø1.0, Ø1.5
T ±0.2:	8.0	T ±0.2:	8.4	T ±0.2:	10.2	T ±0.2:	10.4	10.7	10.5
E ±0.2:	6.1	E ±0.2:	6.7	E ±0.2:	8.2	E ±0.2:	9.1	9.2	9.2
H ±0.2:	0.7+18.3	H ±0.2:	23.5	H ±0.2:	13.9	H ±0.2:	25.8	43.6	13.6
		OD ±0.2:	16.7	H ±0.2:		OD ±0.2:	18.3	18.7	14.8



Tube head No.	A1914	Cap No.	A1911A	A1911B	Tube head No.	A1920	Cap No.	W193
I ±0.2:	Ø1.3	Tube: I ±0.2:	Ø1.3	Ø1.3	I ±0.2:	Ø1.5	I ±0.2:	Ø3.0
T ±0.2:	14.0	T ±0.2:	14.4	14.4	T ±0.2:	16.2	T ±0.2:	16.8
E ±0.2:	12.3	E ±0.2:	13.5	13.5	E ±0.2:	14.9	E ±0.2:	15.7
H ±0.2:	0.5+9.5+10.6	H ±0.2:	22.0	22.3	H ±0.2:	1.5+5.8	H ±0.2:	59.7
		OD ±0.2:	18.2	18.4	OD ±0.2:		OD ±0.2:	18.5



Tube head No.	A2207 Tamper Twist off / Reverse Reusable	Tube head No.	A2208	A2209	Cap No.	A197	A197
I ±0.2:	Ø4.2	I ±0.2:	Ø1.5	Ø1.0	Tube: I ±0.2:	Ø1.5	Ø1.0
T ±0.2:	13.2	T ±0.2:	5.8	5.8	T ±0.2:	6.2	6.2
E ±0.2:	4.5	E ±0.2:	4.8	4.8	E ±0.2:	5.2	5.2
H ±0.2:	0.6+22.8	H ±0.2:	0.5+13.6	0.5+13.6	H ±0.2:	18.1	18.1
					OD ±0.2:	9.3	9.3



Tube head No.	A1915	Cap No.	A1964B	Tube head No.	A1916	Cap No.	A1910
I ±0.2:	OD: 3.0	Tube: I ±0.2:	Ø3.0	I ±0.2:	Ø1.0	Tube: I ±0.2:	Ø1.0
T ±0.2:	ID: 1.5	T ±0.2:	14.6	T ±0.2:	8.6	T ±0.2:	9.0
E ±0.2:	14.2	E ±0.2:	13.0	E ±0.2:	7.0	E ±0.2:	7.6
H ±0.2:	12.4	H ±0.2:	20.7	H ±0.2:	0.5+15.1	H ±0.2:	28.3
H ±0.2:	0.5+5.8+11.2	OD ±0.2:	18.5	OD ±0.2:		OD ±0.2:	18.3

Diameter (mm) : Ø25



A2501, A2502		Cap No. W192	A2552 Pintel Matte	A2551 Pintel Gloss	A251 Gloss	W251 Gloss
I ±0.2:	A2501: Ø4.8	Cap : I ±0.2: Ø1.0	Ø2.5	Ø2.5	/	
T ±0.2:	A2502: Ø2.0-5.0	Tube: I ±0.2: Ø4.8	Ø2.5-Ø6.0	Ø2.5-Ø6.0	Ø2.0, Ø5.0	Ø2.0, Ø5.0
E ±0.2:	8.2	T ±0.2: 10.4	9.3	9.1	10.5	11.0
H ±0.2:	0.5+5.01	E ±0.2: 9.1	10.8	10.8	8.9	9.6
OD ±0.2:		H ±0.2: 25.8	14.4	14.0	12.3	8.6
		OD ±0.2: 18.3	23.9	22.9	23.4	16.8



Cap No.	A221C	A222A+B	A221C+A223A+B
Plug: I ±0.2:	Ø1.0	Ø1.0	Ø1.0
Tube: I ±0.2:	Ø4.8	Ø4.8	Ø4.8
T ±0.2:	4.9	10.5	10.7
E ±0.2:	4.8	9.2	9.2
H ±0.2:	13.4	23.6	43.6
OD ±0.2:	7.8	14.8	18.7



Tube head No.	A2503	A2503-1	Cap No. A253B	A253A
I ±0.2:	Ø1.3	Ø14.7	Plug: I ±0.2: Ø1.4	/
T ±0.2:	20.0	20.1	Tube: I ±0.2: Ø14.7	Ø1.3
E ±0.2:	18.1	18.2	T ±0.2: 14.8	20.8
H ±0.2:	1.0+14.0	1.0+5.3	E ±0.2: 15.1	18.8
			H ±0.2: 14.3	17.8
			OD ±0.2: 14.3	22.8



Tube head No.	A2504 Oval Tube Head	Cap No. A221C	A222A+B
I ±0.2:	Ø4.8	Plug: I ±0.2: Ø1.0	Ø1.0
T ±0.2:	10.2	Tube: I ±0.2: Ø4.8	Ø4.8
E ±0.2:	8.2	T ±0.2: 4.9	10.5
H ±0.2:	0.9+5.4	E ±0.2: 4.8	9.2
OD ±0.5:	28.8/19.6	H ±0.2: 13.4	13.6
		OD ±0.2: 7.8	14.8



Tube head No.	A2505	Cap No. A193 (Matte)
I ±0.2:	Ø1.0	Ø1.0
T ±0.2:	Ø7.9	8.3
E ±0.2:	Ø6.4	6.9
H ±0.2:	3.5+17.7	22.7
OD ±0.2:		19.0

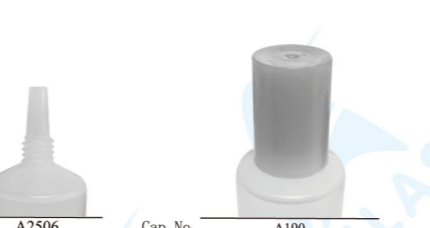

Tube head No.	A2506	Cap No. A190
I ±0.2:	Ø1.0 Ø1.5	Tube: I ±0.2: Ø1.0 Ø1.5
T ±0.2:	8.0	T ±0.2: 8.4
E ±0.2:	6.1	E ±0.2: 6.7
H ±0.2:	0.7+18.3	H ±0.2: 23.5
		OD ±0.2: 16.7



Tube head No.	A2508	Cap No. A1913 Ribbed
I ±0.2:	Ø9.0	Tube: I ±0.2: Ø9.0
T ±0.2:	13.9	T ±0.2: 14.5
E ±0.2:	12.1	E ±0.2: 12.7
H ±0.2:	1.0+9.0	H ±0.2: 12.9
		OD ±0.2: 19.0



Tube head No.	A2509	Cap No. W2509 Vacuum pump
I ±0.2:	Ø9.0	Tube: I ±0.2: Ø9.0
T ±0.2:	16.7	T ±0.2: 17.7
E ±0.2:	14.6	E ±0.2: 15.7
H ±0.2:	1.0+11.7	H ±0.2: 41.4
		Inside cap H ±0.2: 37.4
		Outside cap OD ±0.2: 23.9
		Inside cap OD ±0.2: 21.4

Diameter (mm) : Ø30



Tube head No.	A3001	Cap No. W303 Vacuum pump
I ±0.2:	Ø2.0-7.8	Tube: I ±0.2: Ø7.8
T ±0.2:	14.0	T ±0.2: 12.5
E ±0.2:	12.0	E ±0.2: 14.3
H ±0.2:	1.0+10.8	H ±0.2: 43.5
		OD ±0.2: 29.7



Cap No.	W301	W302 Ball Cap
Tube: I ±0.2:	Ø2.0-6.0	Ø2.0-6.0
T ±0.2:	14.6	14.5
E ±0.2:	12.7	12.7
H ±0.2:	20.4	17.2
OD ±0.2:	28.3	29.6



Tube head No.	A3002	Cap No. A301 Matte Top Gloss Side	A307 Matte Gloss	A3062 Gloss Pintel A3064 Matte Pintel	A304 Ribbed Matte Top
I ±0.2:	Ø2.0-8.0	Tube: I ±0.2: Ø2.0-7.0	Ø2.0-6.0	Ø2.0-8.0	Ø2.0-7.0
T ±0.2:	14.5	T ±0.2: 14.8	14.8	14.8	14.8
E ±0.2:	12.5	E ±0.2: 13.3	12.9	13.2	13.2
H ±0.2:	0.7+6.0	H ±0.2: 12.6	14.2	21.4	12.2
		OD ±0.2: 29.1	28.3	26.9	28.4



Tube head No.	A3003 Oval	Cap No. A302 Oval Cap
I ±0.2:	Ø2.0-4.0	Tube: I ±0.2: Ø2.0-4.0
T ±0.2:	11.0	T ±0.2: 11.5
E ±0.2:	9.4	E ±0.2: 10.1
H ±0.2:	2.2+12.2	H ±0.2: 17.6
OD ±0.5:	35.6 / 22.7	OD ±0.5: 35.2 / 21.8



Tube head No.	A3004	Cap No. A193 Matte
I ±0.2:	Ø1.0	Tube: I ±0.2: Ø1.0
T ±0.2:	Ø7.9	T ±0.2: 8.3
E ±0.2:	Ø6.4	E ±0.2: 6.9
H ±0.2:	3.6+17.7	H ±0.2: 22.4
		OD ±0.2: 19.0



Tube head No.	A3005	Cap No. A305 Ribbed
I ±0.2:	Ø2.0	Tube: I ±0.2: Ø2.0
T ±0.2:	14.4	T ±0.2: 14.8
E ±0.2:	12.5	E ±0.2: 13.2
H ±0.2:	0.7+6.5	H ±0.2: 18.3
		OD ±0.2: 29.7



Tube head No.	A3007	Cap No. A190
I ±0.2:	Ø1.5	Tube: I ±0.2: Ø1.5
T ±0.2:	8.0	T ±0.2: 8.4
E ±0.2:	6.1	E ±0.2: 6.7
H ±0.2:	0.7+18.3	H ±0.2: 23.5
		OD ±0.2: 16.7

Diameter (mm) : ø35

Tube head No.	A3006	Cap No.	A304 Ribbed Matte Top	Silm Oval Tube head No.	A3008	Cap No.	A309
I ±0.2:	Ø3.0	Tube: I ±0.2:	Ø3.0	I ±0.2:	Ø1.5	Tube: I ±0.2:	Ø1.5
T ±0.2:	14.1	T ±0.2:	14.8	T ±0.2:	11.2	T ±0.2:	11.5
E ±0.2:	12.0	E ±0.2:	13.2	E ±0.2:	9.6	E ±0.2:	10.0
H ±0.2:	0.7+5.7	H ±0.2:	12.2	H ±0.2:	2.2+11.4	H ±0.2:	28.0
		OD ±0.2:	28.4	OD ±0.5:	36.6 / 18.7	OD ±0.5:	36.4 / 17.1

Tube head No.	A3501	Cap No.	A356A+B	A356A+C	W352 Ball Cap	A3513	W355	W303 Vacuum pump
I ±0.2:	Ø1.5-7.8	Tube: I ±0.2:	Ø2.0-6.0	Ø2.0-6.0	Ø2.0-7.0	Ø2.0-7.0	Ø2.0-6.0	Ø7.8
T ±0.2:	14.0	T ±0.2:	14.5	14.5	12.4	14.7	14.5	12.5
E ±0.2:	12.0	E ±0.2:	12.7	12.7	18.9	12.8	12.5	14.3
H ±0.2:	0.8+10.8	H ±0.2:	23.8	23.8	34.1	20.5	21.0	43.5
		OD ±0.2:	34.5/36.8	34.5/36.8		33.1	32.3	29.7

Tube head No.	A3010	Cap No.	W305 Octagon Cap	Tube head No.	A3009	Cap No.	W306 Vacuum pump
I ±0.2:	Ø2.0-5.0	Tube: I ±0.2:	Ø2.0-5.0	I ±0.2:	Ø12.7	Tube: I ±0.2:	Ø12.7
T ±0.2:	14.0	T ±0.2:	14.6	T ±0.2:	17.0	T ±0.2:	17.7
E ±0.2:	12.0	E ±0.2:	12.3	E ±0.2:	15.3	E ±0.2:	16.0
H ±0.2:	1.0+10.7	H ±0.2:	12.6	H ±0.2:	2.2+9.7	H ±0.2:	36.4 / 41.7
		OD ±0.2:	21.1	OD ±0.2:	26.1 / 28.6		

Tube head No.	A3502, A3510, A3511	Cap No.	A351 Matte	A354 Matte	A355	A3510	A3515 Pintel	A35191 Donut
I ±0.2:	A3502: Ø2.0-7.0 A3510: Ø5.0 A3511: Ø2.0	Cap: I ±0.2:	Ø2.0-7.0	Ø2.0-7.0	/	Ø2.0-5.0	Ø3.5 Ø5.0	Ø5.0
T ±0.2:	14.5	Tube: I ±0.2:	Ø2.0-7.0	Ø2.0-7.0	Ø2.0-7.0	15.1	Ø2.0-7.0	Ø2.0-7.0
E ±0.2:	12.5	T ±0.2:	15.1	15.3	15.1	15.1	15.3	15.4
H ±0.2:	0.7+6.0	E ±0.2:	13.2	13.6	12.7	16.2	13.3	13.4
		H ±0.2:	13.3	14.0	33.1	33.2	23.8	20.5
		OD ±0.2:	32.8	34.0			33.7	33.7

Tube head No.	A3011	Cap No.	A30121 Pintel	Oval Tube head No.	A3504	Cap No.	A353 Oval Cap	A358	Snap Tube head No.	A3509	Cap No.	A3518 Snap Cap Pintel
I ±0.2:	Ø 5.0	Tube: I ±0.2:	Ø3.0	I ±0.2:	Ø2.0-5.0	Tube: I ±0.2:	Ø2.0-5.0	I ±0.2:	Ø12.4	Tube: I ±0.2:	Ø3.5, Ø5.0	
T ±0.2:	15.1	T ±0.2:	15.3	T ±0.2:	13.0	T ±0.2:	13.5	T ±0.2:	20.6	T ±0.2:	21.0	
E ±0.2:	13.0	E ±0.2:	14.5	E ±0.2:	11.9	E ±0.2:	12.4	E ±0.2:	19.6	E ±0.2:	20.2	
H ±0.2:	1.0+9.0	H ±0.2:	22.7	H ±0.2:	0.8+15.4	H ±0.2:	20.8	H ±0.2:	1.1+10.9	H ±0.2:	22.0	
		OD ±0.2:	27.0	OD ±0.5:	40.3 / 28.0	OD ±0.5:	38.4 / 24.7	OD ±0.5:	37.9 / 24.6	OD ±0.2:	33.5	

Silm Oval Tube head No.	A3503	Cap No.	A352 Slim Oval Cap
I ±0.2:	Ø2.0-5.0	Tube: I ±0.2:	Ø2.0-5.0
T ±0.2:	11.8	T ±0.2:	12.2
E ±0.2:	10.2	E ±0.2:	10.6
H ±0.2:	2.5+11.7	H ±0.2:	20.6
OD ±0.5:	43.5 / 20.3	OD ±0.5:	16.1 / 41.4

	Tube head No. A3513		Cap No. A3512 Snap Cap		Slim Oval Tube head No. A3514		Cap No. A3514 Slim Oval Cap
I ±0.2: Ø5.0		Tube: I ±0.2: Ø3.5		I ±0.2: Ø2.5		Tube: I ±0.2: A3514: (9.7×1.5mm PE liner)	
T ±0.2: 15.1		T ±0.2: 15.4		T ±0.2: 10.7		T ±0.2: 11.3	
E ±0.2: 14.3		E ±0.2: 14.7		E ±0.2: 9.0		E ±0.2: 10.1	
H ±0.2: 0.8+9.2		H ±0.2: 23.8		H ±0.2: 3.0+11.0		H ±0.2: 30.0	
		OD±0.2: 33.7		OD ±0.5: 43.7/21.5		OD±0.5: 43.8 / 18.4	

	Tube head No. A4001		Cap No. A4010		Cap No. A356A+B		Cap No. A356A+C		Cap No. W401		Cap No. W303 Vacuum pump
I ±0.2: Ø2.0-7.8		Tube: I ±0.2: Ø2.0-6.0		Tube: I ±0.2: Ø2.0-6.0		Tube: I ±0.2: Ø2.0-6.0		Tube: I ±0.2: Ø2.0-6.0		Tube: I ±0.2: Ø2.0-6.0	
T ±0.2: 14.0		T ±0.2: 14.9		T ±0.2: 14.5		T ±0.2: 14.5		T ±0.2: 14.8		T ±0.2: 14.8	
E ±0.2: 12.0		E ±0.2: 12.6		E ±0.2: 12.7		E ±0.2: 12.7		E ±0.2: 12.7		E ±0.2: 12.5	
H ±0.2: 1.0+10.7		H ±0.2: 23.9		H ±0.2: 23.8		H ±0.2: 23.8		H ±0.2: 13.6		H ±0.2: 14.3	
		OD±0.2: 36.2		OD±0.2: 34.5/36.8		OD±0.2: 34.5/36.8		OD±0.2: 26.2		OD±0.2: 28.6	

	Tube head No. A3515 Roller Ball Head		Cap No. A3511		Oval Tube head No. A3516		Cap No. Oval Cap A35171 Matte Donut
I ±0.2: /		Tube: I ±0.2: 31.3		Tube: I ±0.2: Ø6.2		I ±0.2: A3516: Ø1.5 Ø3.0 Ø4.0	
T ±0.2: 30.8		E ±0.2: 29.9		T ±0.2: 13.2		A3517: Ø1.5	
E ±0.2: 28.6		H ±0.2: 28.8		E ±0.2: 11.6		A3516: 14.6 14.3	
H ±0.2: 0.6+12.0		OD ±0.2: 34.1		H ±0.2: 1.0+16.2		A3517: 12.6 12.4	
Base OD: 25.0				OD ±0.5: 40.4/28.5		H ±0.2: 24.9 24.9	
						OD ±0.5: 38.0 / 24.4 39.6/	

	Tube head No. A4002		Cap No. A401 matte		Cap No. A4014 Pintal		Cap No. A4019 Donut
I ±0.2: Ø2.0-8.0		Tube: I ±0.2: Ø2.0-7.0		Tube: I ±0.2: Ø3.5 Ø2.0-8.0		Tube: I ±0.2: Ø5.0 Ø2.0-8.0	
T ±0.2: 14.5		T ±0.2: 14.8		T ±0.2: 15.1		T ±0.2: 15.2	
E ±0.2: 12.5		E ±0.2: 13.3		E ±0.2: 13.3		E ±0.2: 13.2	
H ±0.2: 0.7+6.0		H ±0.2: 15.4		H ±0.2: 20.9		H ±0.2: 21.2	
		OD±0.2: 38.3		OD±0.2: 37.5		OD±0.2: 37.5	

	Tube head No. A3517		Cap No. W3517 Vacuum Pump		Tube head No. A3518		Cap No. W3518 Octagon Cap
I ±0.2: Ø12.5		Tube: I ±0.2: Ø12.5		Tube: I ±0.2: Ø2.0-5.0		Tube: I ±0.2: /	
T ±0.2: 16.9		T ±0.2: 17.5		T ±0.2: 14.0		T ±0.2: 14.6	
E ±0.2: 15.3		E ±0.2: 16.1		E ±0.2: 12.0		E ±0.2: 12.3	
H ±0.2: 2.5+9.4		H ±0.2: 42.2		H ±0.2: 1.0+10.7		H ±0.2: 12.6	
		OD±0.2: 33.1/30.1		OD±0.2: 21.1		OD±0.2: 21.1	

	Cap No. A404 Matte		Cap No. A406 Matte Pintal		Cap No. A4016 Pintal
Cap: I ±0.2: /		Tube: I ±0.2: Ø3.5		Tube: I ±0.2: Ø3.5 Ø5.0 Ø6.4	
Tube: I ±0.2: Ø2.0-7.0		T ±0.2: 14.9		T ±0.2: 14.7	
T ±0.2: 14.9		E ±0.2: 13.3		E ±0.2: 13.3	
E ±0.2: 13.1		H ±0.2: 21.0		H ±0.2: 21.0	
H ±0.2: 20.0		OD±0.2: 38.1		OD±0.2: 37.6	
OD±0.2: 37.8					

Diameter (mm) : ø38 & ø40

	Slim Oval Tube head No. A4003		Cap No. A403 Slim Oval Cap		Oval Tube head No. A4004		Cap No. A402 Oval Cap		Tube head No. A4005		Cap No. A252A+B
I ±0.2: Ø2.0-5.0		Tube: I ±0.2: 13.4		Tube: I ±0.2: Ø2.0-5.0		Tube: I ±0.2: Ø2.0-5.0		Tube: I ±0.2: Ø2.0-5.0		Tube: I ±0.2: Ø2.0-7.0	
T ±0.2: 12.9		T ±0.2: 13.4		T ±0.2: 13.4		T ±0.2: 13.4		T ±0.2: 15.0		T ±0.2: 15.8	
E ±0.2: 11.9		E ±0.2: 12.1		E ±0.2: 11.9		E ±0.2: 12.2		E ±0.2: 13.1		E ±0.2: 13.9	
H ±0.5: 2.4+12.6		H ±0.2: 24.1		H ±0.2: 0.7+15.3		H ±0.2: 20.7		H ±0.2: 0.8+15.8		H ±0.2: 30.4	
OD ±0.5: 49.7/25.6		OD±0.5: 49.5/21.5		OD ±0.2: 47.7/30.7		OD±0.5: 48.1 / 27.3		OD ±0.2: 47.9/30.5		OD±0.2: 24.0	

	Tube head No. A3801		Cap No. W381 Pintal		Cap No. A4011
I ±0.2: Ø2.0-11.0		Cap: I ±0.2: Ø6.4 Ø5.0 Ø3.5		Tube: I ±0.2: Ø2.0-11.0	
T ±0.2: 21.7		Tube: I ±0.2: Ø2.0-11.0		T ±0.2: 22.0	
E ±0.2: 19.2		T ±0.2: 22.2		E ±0.2: 19.7	
H ±0.2: 0.8+9.0		E ±0.2: 19.7		H ±0.2: 16.8	
		H ±0.2: 25.5		OD ±0.2: 37.8	
		OD±0.2: 37.3			

Oval Tube head No.	A4006	Cap No.	W409 Donut	Tube head No.	A4007	Cap No.	A407 Pintle Oval Snap Cap
I ±0.2:	Ø6.0	SnapTube: I ±0.2:	Ø5.0 , Ø3.5	I ±0.2:	Ø9.5	Cap: I ±0.2:	Ø5.0
T ±0.2:	16.5	T ±0.2:	17.3	T ±0.2:	44/27.0	Tube: I ±0.2:	Ø 9.5
E ±0.2:	14.2	E ±0.2:	15.5	H ±0.2:	19.5	T ±0.2:	44.8 / 27.5
H ±0.2:	0.8+17.8	H ±0.2:	26.1	OD ±0.2:	46.6 / 31.3	E ±0.2:	43.9
OD ±0.2:	46.1 / 32.2	OD±0.5:	44.1 / 28.3			H ±0.2:	28.3
						OD±0.5:	46.8 / 29.6

Tube head No.	A4505	Cap No.	A455 A+B+C Donut	Tube head No.	A4504	Cap No.	A453 Donut Snap Cap
I ±0.2:	Ø16.0	Cap: I ±0.2:	Ø4.0	I ±0.2:	Ø12.0	Cap: I ±0.2:	Ø5.0 Ø8.0
T ±0.2:	21.1	T ±0.2:	22.2	T ±0.2:	21.4	Tube: I ±0.2:	Ø12.0
E ±0.2:	19.4	E ±0.2:	20.5	E ±0.2:	20.2	T ±0.2:	21.9
H ±0.2:	19.6+16.0	H ±0.2:	50.0	H ±0.2:	1.0+10.3	E ±0.2:	21.1
		OD ±0.2:	42.6			H ±0.2:	25.8
						OD ±0.2:	39.8

Tube head No.	A4008	Cap No.	A4011 matte	Oval Tube head No.	A4009	Cap No.	A4013 Oval Cap
I ±0.2:	Ø2.0-8.0	Tube: I ±0.2:	Ø2.0-10.0	I ±0.2:	Ø2.8	Tube: I ±0.2:	Ø2.8
T ±0.2:	21.2	T ±0.2:	22.0	T ±0.2:	17.7	T ±0.2:	18.7
E ±0.2:	18.7	E ±0.2:	19.7	E ±0.2:	15.0	E ±0.2:	15.7
H ±0.2:	0.8+9.5	H ±0.2:	16.8	H ±0.2:	3.6+16.0	H ±0.2:	27.8
		OD ±0.2:	37.8	OD ±0.2:	45.9 / 33.6	OD ±0.5:	45.9 / 29.4

Tube head No.	A4506	Cap No.	A456 A+B+C Disk Cap
I ±0.2:	Ø18.0	Cap: I ±0.2:	Ø5.8
T ±0.2:	23.6	T ±0.2:	24.5
E ±0.2:	21.7	E ±0.2:	22.3
H ±0.2:	19.6+13.4+9.9	H ±0.2:	42.5
		OD ±0.2:	43.9

Diameter (mm) : ø50

Tube head No.	A4013	Cap No.	A4018 Eco-Pintle Thin Cap	Tube head No.	A4010	Cap No.	A4015 Snap Cap Pintle
I ±0.2:	Ø13.3	Tube: I ±0.2:	Ø5.0	I ±0.2:	Ø10.0	Tube: I ±0.2:	Ø3.5 Ø5.0 Ø6.4
T ±0.2:	21.6	T ±0.2:	21.9	T ±0.2:	21.4	T ±0.2:	21.8
E ±0.2:	19.9	E ±0.2:	19.8	E ±0.2:	/	E ±0.2:	21.1
H ±0.2:	1.2+3.2	H ±0.2:	7.1	H ±0.2:	1.0+7.4	H ±0.2:	21.0
		OD ±0.2:	38.5	OD ±0.2:	37.4		

Tube head No.	A5001, A5002	Cap No.	A505	A501 Matte	Cap No.	A50102 Pintle Gloss A503 Donut Matte	Cap No.	A5010 Pintle	
I ±0.2:	A5001: Ø3-10 A5002: 6.35	Cap: I ±0.2:	/	Tube: I ±0.2:	Ø2.0-10.0	Cap: I ±0.2:	Ø5.0	Cap: I ±0.2:	Ø5.0
T ±0.2:	21.5	Tube: I ±0.2:	Ø2.0-10.0	T ±0.2:	22.0	Tube: I ±0.2:	Ø2.0-10.0	Tube: I ±0.2:	Ø2.0-10.0
E ±0.2:	18.6	T ±0.2:	22.0	E ±0.2:	19.6	T ±0.2:	21.9	T ±0.2:	A5010: 21.9
H ±0.2:	1.0+9.0	E ±0.2:	19.6	H ±0.2:	22.3	E ±0.2:	19.5	E ±0.2:	A5010: 19.5
		H ±0.2:	22.3	OD ±0.2:	46.0	H ±0.2:	A50102 : 25.0	H ±0.2:	A5010: 25.6
		OD ±0.2:	46.0			OD ±0.2:	A503: 25.0	OD ±0.2:	47.6
							A50102 : 47.2		
							A503: 47.7		

Diameter (mm) : ø45

Tube head No.	A4501	Cap No.	A452	Cap No.	A454 Pintle Pintle
I ±0.2:	Ø2.0-8.0	Tube: I ±0.2:	Ø2.0-10.0	Cap: I ±0.2:	Ø5.0
T ±0.2:	21.5	T ±0.2:	22.0	Tube: I ±0.2:	Ø2.0-8.0
E ±0.2:	18.6	E ±0.2:	19.7	T ±0.2:	22.4
H ±0.2:	1.0+9.0	H ±0.2:	21.7	E ±0.2:	19.7
		OD ±0.2:	42.6	H ±0.2:	24.1
				OD ±0.2:	42.7

Tube head No.	A5003	Cap No.	A506 Snap Cap Pintle	Oval Tube head No.	A5004	Cap No.	A5011 Oval Cap Donut
I ±0.2:	Ø11.6	Cap: I ±0.2:	Ø5.0	I ±0.2:	Ø10.0	Cap: I ±0.2:	Ø3.5, Ø5, Ø6
T ±0.2:	21.4	Tube: I ±0.2:	Ø12.0	T ±0.2:	21.4	Tube: I ±0.2:	Ø10.0
E ±0.2:	20.1	T ±0.2:	21.5	E ±0.2:	19.4	T ±0.2:	22.2
H ±0.2:	1.3+9.5	E ±0.2:	20.5	H ±0.2:	2.4 / 18.8	E ±0.2:	20.2
		H ±0.2:	25.5	OD ±0.2:	58.8 / 39.7	H ±0.2:	29.8
		OD ±0.2:	47.6			OD ±0.5:	33.6 / 56.3

Fragrance Caps (15mm, 13mm)



head No.	A5005	Cap No.	A502 Pinal Oval Snap Cap
I ±0.2:	Ø9.8	Cap: I ±0.2:	Ø5.0, Ø8.0
T ±0.2:	34.9 / 55.7	Tube: I ±0.2:	Ø9.8
E ±0.2:	34.1 / 54.7	T ±0.2:	57.2
H ±0.2:	19.4	E ±0.2:	56.2
OD ±0.2:	58.1 / 39.8	H ±0.2:	28.3
		OD ±0.5:	59.2 / 37.2



head No.	A5006	A504	A504 Oval Cap
I ±0.2:	Ø2.5	Cap: I ±0.2:	/
T ±0.2:	19.7	Tube: I ±0.2:	Ø2.5
E ±0.2:	16.6	T ±0.2:	20.7
H ±0.2:	1.4+16.7	E ±0.2:	17.5
OD ±0.5:	57.5 / 40.8	H ±0.2:	30.9
		OD ±0.5:	58.3 / 36.4



A-ZS02
 Cap: H ±0.2: 29.53
 OD ±0.5: 42.08/28.3



A-ZS07
 Cap: H ±0.2: 22.93
 OD ±0.5: 33.54/22.64



A-ZS04
 Cap: H ±0.2: 26.76
 OD ±0.5: 45.13/25.22



A-00401
 Cap: H ±0.2: 15.4
 OD ±0.5: 30.06/17.58



A-0179
 Cap: H ±0.2: 12.7
 OD ±0.5: 26.0



A-0269
 Cap: H ±0.2: 14.36
 OD ±0.5: 21.6



A-0256
 Cap: H ±0.2: 22.17
 OD ±0.5: 15.48



Tube head No. A5007
 I ±0.2: Ø12.0
 T ±0.2: 21.4
 E ±0.2: 20.2
 H ±0.2: 1.0+10.3



Cap No. A453 Donut Snap Cap
 Cap: I ±0.2: Ø5.0 Ø8.0
 Tube: I ±0.2: Ø12.0
 T ±0.2: 21.9
 E ±0.2: 21.1
 H ±0.2: 25.8
 OD ±0.2: 39.8



Tube head No. A4505
 I ±0.2: Ø16.0
 T ±0.2: 21.1
 E ±0.2: 19.4
 H ±0.2: 24.5+16.0



Cap No. A5013 A+B+C Donut
 Cap: I ±0.2: Ø4.0
 T ±0.2: 22.2
 E ±0.2: 20.5
 H ±0.2: 55.4
 OD ±0.2: 47.8

Diameter (mm) : Ø60



Tube head No. A5008
 I ±0.2: Ø3-10
 T ±0.2: 21.1
 E ±0.2: 18.8
 H ±0.2: 1.0+14.0
 18.9+1.0+14.0+14.0



Cap No. A5012A+B+C
 Cap: T ±0.2: 21.6
 E ±0.2: 19.4
 H ±0.2: 51.7
 OD ±0.2: 48.1



Tube head No. A6001
 I ±0.2: Ø6-12
 T ±0.2: 21.5
 E ±0.2: 18.6
 H ±0.2: 1.3+9.3



Cap No. W601 Donut Cap
 Cap: I ±0.2: Ø6.0
 Tube: I ±0.2: Ø6.0-12
 T ±0.2: 22.0
 E ±0.2: 19.8
 H ±0.2: 28.2
 OD ±0.2: 56.7



A-H01
 Cap: H ±0.5: 31.2
 W ±0.5: 48.2 / 44.3



A-0096
 Cap: H ±0.2: 47.7
 OD ±0.5: 29.7



A-0261
 Cap: H ±0.2: 32.4
 OD ±0.5: 23.5



A-0260
 Cap: H ±0.2: 27.5
 OD ±0.5: 20.0

Flip-top caps-Jars



A-P02 Ø44mm



A-P06 Ø44mm



A-P08 Ø44mm



A-P01 Ø38mm



A-P05 Ø38mm



A-P07 Ø38mm

Custom Tube Caps



Cap No.	A224A+B
Cap T ±0.2:	15.7
E ±0.2:	14.1
H ±0.2:	27.8
OD ±0.2:	22.4



Cap No.	A0138A
Cap T ±0.2:	14.6
E ±0.2:	12.8
H ±0.2:	36.48
OD ±0.2:	23.37



Cap No.	A30111A+B
Cap T ±0.2:	11.5
E ±0.2:	10.1
H ±0.2:	18.3
OD ±0.2:	36.6/18.2



Cap No.	A3010A+B+C
Cap T ±0.2:	15.3
E ±0.2:	13.3
H ±0.2:	22.6
OD ±0.2:	29.9



Cap No.	A0094A+B+C
Cap T ±0.2:	24.33
E ±0.2:	22.0
H ±0.2:	35.5
OD ±0.2:	49.7



Cap No.	A5014
Cap T ±0.2:	21.9
E ±0.2:	19.7
H ±0.2:	24.4
OD ±0.2:	47.1



Cap No.	A-0277
Cap T ±0.2:	15.2
E ±0.2:	13.5
H ±0.2:	24.9
OD ±0.2:	34.0



Cap No.	A-0262
Cap T ±0.2:	15.3
E ±0.2:	13.6
H ±0.2:	28.4
OD ±0.2:	38.7

Labelling

1、 Labelling Direction:

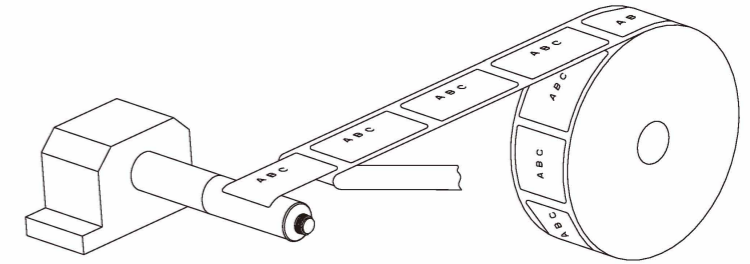

2、 Labelling parameter

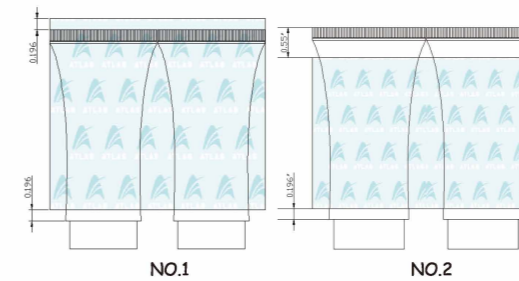

NO.1-NO.2 for Ø13-Ø60

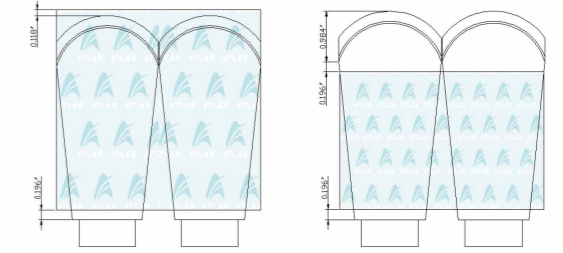

NO.3 for Ø35、Ø40、Ø50

NO.4 for Ø35

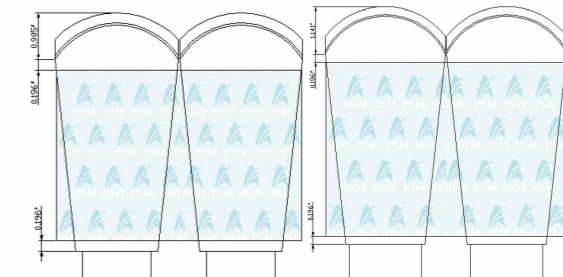

NO.5 for Ø40

NO.6 for Ø50

Beauty Foil Tube

(6 layer co-ex foil tube)



Size : D22mm, D25mm, D30mm, D40mm, D45mm, D50mm .
Printing: up to 5 color Silkscreen

Advantages:

- ◆ Exhibit high barrier and preservation properties
- ◆ Protection against light
- ◆ Diffusion-tight
- ◆ Excellent moisture barrier
- ◆ High impermeability to organic and chemical substances
- ◆ Corrosion resistant

Tube end sealing Styles

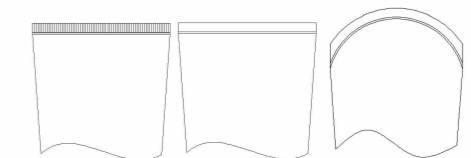

Vertical Ø16-Ø60
Horizontal Ø16-Ø60
Curved Ø35、Ø40、Ø50

Diameter		Round Tube/Beautyfoil Tube sizes (Length in mm/ Inches)											
Length mm Inches	Capacity ml fl oz	1/2"	5/8"	3/4"	7/8"	1"	1 3/16"	1 3/8"	1 1/2"	1 9/16"	1 3/4"	2"	2 3/8"
		Ø13mm	Ø16mm	Ø19mm	Ø22mm	Ø25mm	Ø30mm	Ø35mm	Ø38mm	Ø40mm	Ø45mm	Ø50mm	Ø60mm
3	0.10	50 / 1.97"											
4	0.14	55 / 2.17"											
5	0.17	64 / 2.52"	51 / 2.01"	49 / 1.93"									
6	0.20	72 / 2.83"	55 / 2.17"	52 / 2.05"									
7	0.24	80 / 3.15"	59 / 2.32"	58 / 2.28"									
8	0.27	88 / 3.46"	64 / 2.52"	60 / 2.36"									
10	0.34		71 / 2.80"	65 / 2.56"	59 / 2.32"								
15	0.51		88 / 3.46"	83 / 3.27"	72 / 2.83"	60 / 2.36"							
18	0.60		100 / 3.94"	93 / 3.66"	80 / 3.15"	68 / 2.68"							
20	0.68		110 / 4.33"	101 / 3.98"	85 / 3.35"	71 / 2.80"							
25	0.85			120 / 4.72"	98 / 3.86"	82 / 3.23"	70 / 2.76"						
30	1.00			140 / 5.51"	111 / 4.37"	94 / 3.70"	78 / 3.07"						
35	1.18				124 / 4.88"	106 / 4.17"	85 / 3.35"						
40	1.35				137 / 5.39"	117 / 4.61"	92 / 3.62"	79 / 3.11"					
45	1.52					126 / 4.96"	99 / 3.90"	83 / 3.27"	75 / 2.95"				
50	1.69					137 / 5.39"	106 / 4.17"	89 / 3.50"	80 / 3.15"	77 / 3.03"			
55	1.86					148 / 5.83"	113 / 4.45"	96 / 3.78"	85 / 3.35"	83 / 3.27"			
60	2.00					120 / 4.72"	101 / 3.98"	91 / 3.58"	87 / 3.43"				
65	2.20					127 / 5.00"	107 / 4.21"	94 / 3.70"	90 / 3.54"				
70	2.37					134 / 5.28"	113 / 4.45"	98 / 3.86"	95 / 3.74"				
75	2.54					141 / 5.55"	119 / 4.69"	104 / 4.09"	99 / 3.90"				
80	2.71					148 / 5.83"	125 / 4.92"	110 / 4.33"	105 / 4.13"	85 / 3.35"			
85	2.87					155 / 6.10"	131 / 5.16"	115 / 4.53"	110 / 4.33"	90 / 3.54"			
90	3.04						137 / 5.39"	120 / 4.72"	115 / 4.53"	95 / 3.74"	87 / 3.43"		
100	3.38						149 / 5.87"	130 / 5.12"	122 / 4.80"	101 / 3.98"	94 / 3.70"		
110	3.72						161 / 6.34"	141 / 5.55"	130 / 5.12"	107 / 4.21"	101 / 3.98"		
120	4.06						173 / 6.81"	151 / 5.94"	138 / 5.43"	114 / 4.49"	107 / 4.21"		
130	4.40							162 / 6.38"	146 / 5.75"	120 / 4.72"	113 / 4.45"		
140	4.73							172 / 6.77"	154 / 6.06"	127 / 5.00"	119 / 4.69"		
150	5.07							183 / 7.20"	162 / 6.38"	134 / 5.28"	125 / 4.92"		
160	5.41								170 / 6.69"	140 / 5.51"	131 / 5.16"		
170	5.75								179 / 7.05"	147 / 5.79"	137 / 5.39"		
180	6.09								187 / 7.36"	153 / 6.02"	143 / 5.63"	117 / 4.61"	
190	6.43									160 / 6.30"	149 / 5.87"	121 / 4.76"	
200	6.76									167 / 6.57"	155 / 6.10"	124 / 4.88"	
210	7.10									173 / 6.81"	161 / 6.34"	127 / 5.00"	
220	7.44									179 / 7.05"	167 / 6.57"	130 / 5.12"	
230	7.78									185 / 7.28"	173 / 6.81"	133 / 5.24"	
240	8.12									191 / 7.52"	179 / 7.05"	138 / 5.43"	
250	8.45									197 / 7.76"	185 / 7.28"	143 / 5.63"	
260	8.79									203 / 7.99"	191 / 7.52"	148 / 5.83"	
280	9.47										202 / 7.95"	154 / 6.06"	
300	10.14											160 / 6.30"	
350	11.83											179 / 7.05"	
400	13.52											196 / 7.72"	
450	15.21											213 / 8.39"	
500	16.91											230 / 9.06"	

*Beautyfoil Sizes "✓"

Oval/ Slim Oval Tube Sizes (Length in mm/ Inches)											
Length mm Inches	Capacity ml FL Oz	Diameter mm Inches	Oval					Slim Oval			
			1"	1 3/16"	1 3/8"	1 9/16"	1 3/4"	2"			
			Ø25mm	Ø30mm	Ø35mm	Ø40mm	Ø45mm	Ø50mm			
20	0.68		78 / 3.07"								
25	0.85		85 / 3.35"	80 / 3.15"							
30	1.00		90 / 3.54"	85 / 3.35"							
35	1.18		97 / 3.82"	93 / 3.66"							
40	1.35		104 / 4.09"	100 / 3.94"							
45	1.52			107 / 4.21"	90 / 3.54"						
50	1.69			114 / 4.49"	95 / 3.74"						
55	1.86			121 / 4.76"	100 / 3.94"						
60	2.00				105 / 4.13"	90 / 3.54"					
65	2.20				111 / 4.37"	95 / 3.74"					
70	2.37				117 / 4.61"	100 / 3.94"					
75	2.54				124 / 4.88"	105 / 4.13"					
80	2.71				130 / 5.12"	108 / 4.25"					
85	2.87				136 / 5.35"	111 / 4.37"					
90	3.04					115 / 4.53"	103 / 4.06"				
100	3.38					119 / 4.69"	110 / 4.33"				
110	3.72					130 / 5.12"	117 / 4.61"				
120	4.06					140 / 5.51"	124 / 4.88"	110 / 4.33"			
130	4.40					146 / 5.75"	131 / 5.16"	115 / 4.53"			
140	4.73						137 / 5.39"	120 / 4.72"			
150	5.07						143 / 5.63"	125 / 4.92"			
160	5.41						149 / 5.87"	130 / 5.12"			
170	5.75						155 / 6.10"	135 / 5.31"			
180	6.09						161 / 6.34"	140 / 5.51"			
190	6.43						166 / 6.54"	145 / 5.71"			
200	6.76						171 / 6.73"	150 / 5.91"			
210	7.10							158 / 6.22"			
220	7.44							163 / 6.41"			
230	7.78							168 / 6.61"			
240	8.12							173 / 6.81"			
250	8.45							178 / 7.01"			
260	8.79							183 / 7.20"			
280	9.47							193 / 7.60"			
300	10.14							203 / 7.99"			



Length mm	Inches mm	Round Tube/Beautyfoil Tube Sizes (Length in mm)											
		Diameter											
		1/2"	5/8"	3/4"	7/8"	1"	1 3/16"	1 3/8"	1 1/2"	1 9/16"	1 3/4"	2"	2 3/8"
Capacity ml fl oz	Ø13mm	Ø16mm	Ø19mm	Ø22mm	Ø25mm	Ø30mm	Ø35mm	Ø38mm	Ø40mm	Ø45mm	Ø50mm	Ø60mm	
3	0.10	50											
4	0.14	55											
5	0.17	64	51	49									
6	0.20	72	55	52									
7	0.24	80	59	58									
8	0.27	88	64	60									
10	0.34		71	65	59								
15	0.51		88	83	72	60							
18	0.60		100	93	80	68							
20	0.68		110	101	85	71							
25	0.85			120	98	82	70						
30	1.00			140	111	94	78						
35	1.18				124	106	85						
40	1.35				137	117	92	79					
45	1.52					126	99	83	75				
50	1.69					137	106	89	80	77			
55	1.86					148	113	96	85	83			
60	2.00						120	101	91	87			
65	2.20						127	107	94	90			
70	2.37						134	113	98	95			
75	2.54						141	119	104	99			
80	2.71						148	125	110	105	85		
85	2.87						155	131	115	110	90		
90	3.04							137	120	115	95	87	
100	3.38							149	130	122	101	94	
110	3.72							161	141	130	107	101	
120	4.06							173	151	138	114	107	
130	4.40								162	146	120	113	
140	4.73								172	154	127	119	
150	5.07								183	162	134	125	
160	5.41									170	140	131	
170	5.75									179	147	137	
180	6.09									187	153	143	117
190	6.43										160	149	121
200	6.76										167	155	124
210	7.10										173	161	127
220	7.44										179	167	130
230	7.78										185	173	133
240	8.12										191	179	138
250	8.45										197	185	143
260	8.79										203	191	148
280	9.47											202	154
300	10.14												160
350	11.83												179
400	13.52												196
450	15.21												213
500	16.91												230

*Beautyfoil Sizes "✓"



Length mm	Diameter mm	Inches	Oval/ Slim Oval Tube Sizes (Length in mm)					
			Diameter					
			1"	1 3/16"	1 3/8"	1 9/16"	1 3/4"	2"
Capacity ml FL Oz	Oval	Ø25mm	Ø30mm	Ø35mm	Ø40mm	Ø45mm	Ø50mm	
			Ø25mm	Ø30mm	Ø35mm	Ø40mm	Ø45mm	Ø50mm
20	0.68		78					
25	0.85		85	80				
30	1.00		90	85				
35	1.18		97	93				
40	1.35		104	100				
45	1.52			107	90			
50	1.69			114	95			
55	1.86			121	100			
60	2.00				105	90		
65	2.20				111	95		
70	2.37				117	100		
75	2.54				124	105		
80	2.71				130	108		
85	2.87				136	111		
90	3.04					115	103	
100	3.38					119	110	
110	3.72					130	117	
120	4.06					140	124	110
130	4.40					146	131	115
140	4.73						137	120
150	5.07						143	125
160	5.41						149	130
170	5.75						155	135
180	6.09						161	140
190	6.43						166	145
200	6.76						171	150
210	7.10							158
220	7.44							163
230	7.78							168
240	8.12							173
250	8.45							178
260	8.79							183
280	9.47							193
300	10.14							203



Atlas Plastic Products (HK) Company Limited
 香港九龍佐敦上海街28號恒邦商業中心18樓1809室
 電話：(852) 23180956/23180957
深圳雅利士塑膠制品有限公司
 深圳市龍崗區坪山街道石井社區創業路2號
 電話：0755-89923692
 傳真：0755-89923625
 E-mail: info@atlasplastics.com

atlasplastics.com

Atlas Plastic Products (HK) Company Limited
 HK Office: Unite 1809, 18th Floor, Hang Bong Commercial Centre,
 28 Shanghai Street, Jordan, Kowloon. Hong Kong
 Tel: (852) 23180956 / 23180957
ShenZhen Atlas Plastic Products Company Limited
 2 Chuangye Road, Shijing Village, Pingshan New District,
 Shenzhen, China
 Tel: 0755-89923692 Fax: 0755-89923625
 E-mail: info@atlasplastics.com

Product Catalogue

Professional Cosmetics Packaging Supplier

atlasplastics.com